

# Improving Performance and Prolongation of Electric Motors by Advanced Control Scheme in Nigeria Manufacturing Industry: An Issue to Sustain Production and Marketing of Industrial Products

<sup>1</sup>Ahmed U. Omeiza, <sup>2</sup>Caleb A. Amlabu and <sup>3</sup>Iliya Bawa

<sup>1&2</sup>Department of Electrical/Electronic Engineering Technology, Federal Polytechnic Nasarawa, P.M.B 01, Nasarawa, Nasarawa State, Nigeria

<sup>3</sup>Department of Marketing, Federal Polytechnic Nasarawa, P.M.B 01, Nasarawa, Nasarawa State, Nigeria

Corresponding Author E-mail: iliyabawa84@gmail.com

**Received:** May 15, 2019; **Accepted:** May 22, 2019; **Published:** May 26, 2019

**Abstract:** Most manufacturing industries in Nigeria operate electrical machines for industrial processes without optimizing the performance of the electric motors used by them. Poor control and maintenance of these motors has led to unsustainable production due to the failure of the motors. The objective of the study is to illustrate how a feedback control system can be used to prolong electric motors' life-span, point out the need to analyze electric motors aided by computer simulation via modeling of motor parameters that can translate to hardware implementation aimed at improving their performance and point out ways by which revenue can be generated from the sales of electric motors. The study employed a content analysis based on relevant data gathered from journals, books, websites and compiled databases which were analyzed to give a complete understanding of the possible causes of electric motor failures in Nigerian manufacturing industries. The findings reveal that poor performance and reduced life-span is a result of zero or poor control of the electric motors. Using an advanced control system approach aided by computer simulation application compared to the conventional method of control of electric motors entails modeling, analyzing and controlling electric motors using orthogonal dq-axis transformation of the electric motor phase windings. The study concluded that to sustain production in Nigerian manufacturing industries using feedback control system application to electric motors will improve their performance and prolongation. The study recommended that adequate sensitization should be carried out by the manufacturing association of Nigeria (MAN) on the need to optimize electric motors usage in industries and adopt the advanced control strategy.

**Keywords:** Manufacturing Industries, control, electric-motors, simulation, marketing.

**Citation:** Ahmed U. Omeiza, Caleb A. Amlabu and Iliya Bawa. 2019. Improving Performance and Prolongation of Electric Motors by Advanced Control Scheme in Nigeria Manufacturing Industry: An Issue to Sustain Production and Marketing of Industrial Products. International Journal of Current Innovations in Advanced Research, 2(5): 51-59.

**Copyright:** This is an open-access article distributed under the terms of the Creative Commons Attribution License, which permits unrestricted use, distribution, and reproduction in any medium, provided the original author and source are credited.

**Copyright©2019;** Ahmed U. Omeiza, Caleb A. Amlabu and Iliya Bawa.

## Introduction

Production by Nigeria manufacturing industries need to be sustained by ensuring that electric motors used in production are maintained in such conditions that guarantee their optimum performance and prolong usage. This is necessary considering the role played by electric motors in industries as evident from its various applications in processing, agriculture, food, oil, gas, mining, packaging, textile, paper and steel. There are certain indices used to measure the performance of these motors and includes transient response, steady-state error and percentage overshoot. However, these motors rarely measure up to the intended performance as they are affected by elements such as environmental temperature, power supply voltage, winding specifications etc. Moreover, there are issues of electric motors not attaining their actual life-span owing to vibration, over-heating, moisture, accumulation of dirt, over current and low insulation resistance. Apart from the convention control measures normally employed to improve motor performance it is required to adopt advanced mode of control characterized by unitized monitoring of each motor with feedback control aimed at prolonging the life-span of the motors. This mode of control also uses Matlab Simulink modelling approach to improving the electric motor performance.

## Statement of the Problem

Most manufacturing industries in Nigeria operates electrical machines for industrial processes without optimizing the performance of the electrical motors used by them. Besides, poor control and maintenance of these motors has led to unsustain production due to the failure of the motors.

## Objectives of the Study

- i) To illustrate how feedback control system can be used to prolong electric motors life-span in addition to improving their performance.
- ii) To enlighten industrial operatives the need to analyze electrical motors aided by computer simulation via modelling of motor parameters that can translate to hardware implementation aim at improving their performance.
- iii) To point out ways by which revenue can be generated from the sales of electric motors.

## Research Methodology

The research methodology employed involved gathering relevant data, information and diagrammatic illustrations from relevant documents (such as journals, books, websites) and compiled database which were analyzed to give a complete understanding of the possible causes of electric motor failures in the Nigerian manufacturing industries, from which conclusion and recommendation were made.

## Literature Review

### Role of Electric Motor in Industrial Production

From the tiniest motor found in a quartz wrist-watch to a horse power motor powering a ship, electric motors have found in diverse applications. A world without electric motors is difficult to imagine (Keyes, 2007). Every aspect of modern living is impacted by electric motors as computer hard drives, refrigerators, air conditioners, vacuum cleaners, fans and multitudes of other devices use electric motors to convert electrical energy into useful mechanical energy. In addition, electric motors are also responsible for a very large portion of industrial processes as they are used at some point in the manufacturing process of nearly every conceivable product that is produced in modern factories. Because of the nearly unlimited number of applications of electric motors, it is not hard to imagine that there are large number of motors of various sizes in operation across the world industries.

Besides there are a multitude of motor types to choose from, each with its own unique characteristics, making one motor type a better choice for an application than the other. Some of the areas in which electric motors can find application in various industry types are listed below:

- ✓ Process Industry: agitators, pumps, fans, and compressors
- ✓ Agriculture Industry: conveyors, dryer fans and blowers
- ✓ Food Industry: conveyors, mixers and fans
- ✓ Oil, Gas, and Mining Industries: cranes, compressors, pumps and shovels
- ✓ Packaging Industry: shears
- ✓ Paper and Steel Industry: hoists, and rollers
- ✓ Textile Industry: looms
- ✓ All Industries (requiring heating, ventilating and air conditioning): blowers, fans, and compressors.

### Performance Index of Electric Motors

According to Sao and Singh (2015), motors are used to give rotary speed and position to a various electromechanical system by providing efficient speed control for both acceleration and deceleration mode with effective torque control. High performance motor drives development is very important for industrial applications necessitating dynamic control systems with performance specified in terms of both the transient response and the steady-state response of the motor.

With reference to Figure 1, the transient response is the response that disappears with time. The steady-state is the response that exists for a long time following an input signal initiation (Dorf and Bishop, 2008). Thus performance index of electric motors includes producing the desired transient response, reducing steady-state error, and achieving stability. Hence, a motor having high performance is measured as that which rotate at desired speed at zero steady-state error with or without disturbance, in addition to exhibiting improved transient response as a result of quick settling time and very low percentage overshoot. Furthermore, an improved motor transient response and zero steady-state error in motor speed leads to improved stability of the electric motor.

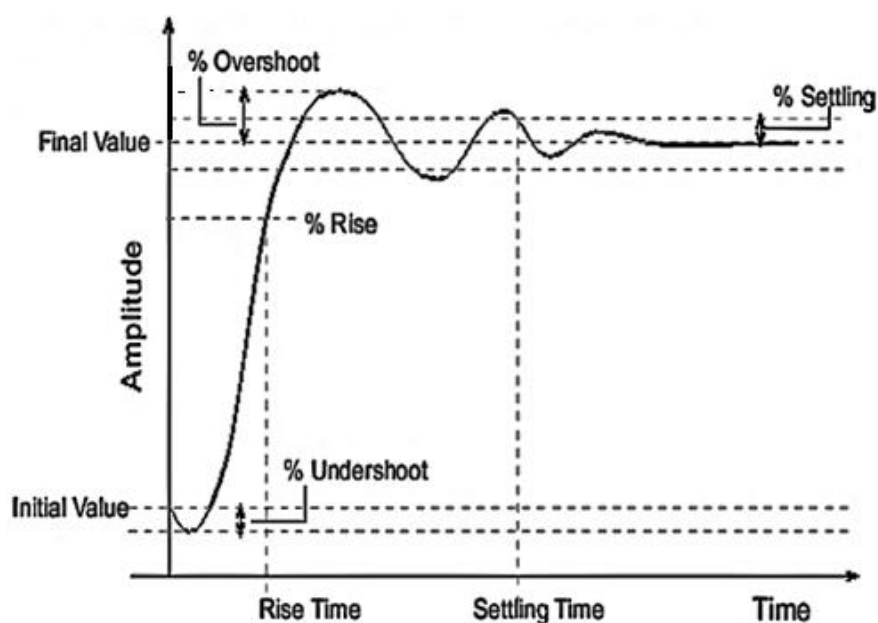

Figure 1. Time response characteristics

### Factors that Affects the Performance of Electric Motors

According to the website mabuchi-motor, three elements such as voltage across terminals, resistance across terminals, and magnetic force affects motor performance. Various factors that changes the performance of motors and influence these three elements includes: power supply voltage; type of power supply; winding specification; environmental temperature; flux yoke; phase.

**1) Voltage of Power Supply:** Change in motor performance is in direct proportion to that change in voltage.

**2) Type of Power Supply:** A dc power supply unlike ac power supply will have voltage drop due to its internal resistance causing the motor stall torque to drop with speed.

**3) Winding Specification:** Increased number of turns per slot results in a drop in speed in direct proportion. Increase in diameter of magnet wire results in increasing stall torque in inverse proportion of the wire diameter raised to the second power.

**4) Environmental Temperature:** Environmental temperature affects the magnetic forces of magnets and the winding resistance, so indicates changes in motor performance.

**5) Flux Yoke:** Using thin-wall housing for magnet will result in magnetic force leaking through the housing wall. Hence magnet yokes are used to prevent magnetic leakage.

**6) Phase:** This is the positional relations between the axial line of each polar magnet and the switching position of commutator segments and brushes. Motors that runs under load lagging momentarily in the electrical phase due to its phenomenal armature reaction causes inefficiency, electrical noise. This situation is avoided using improved motors assembled with forward brush-shifting that offsets the armature reaction during load operation to keep them on neutral electrically. However, when running in the reverse direction, will have, due to resultant lagging phase angle, adverse effects resulting in poor commutation, undesirable electrical noise, and shorter life. For this reason, the motors must be run in one direction only.

### Factors that Shorten the Life-Span of Electric Motors

Mirza (2013) discussed the factors that shortens the life-span of electric motors, stating that the inherent long service life of motors meant that minimum level of maintenance is required by most of them to ensure they perform efficiently. The main causes of failure of electric motor include:

**1) Vibration:** which is caused by corrosion of motor parts and misalignment of motor.

**2) Over heating:** occurs when electric motors are subjected to high-temperature environment causing motor winding insulation to deteriorate quickly.

**3) Moisture:** brings about the corrosion of the motor shafts, bearings and rotors which can lead to an insulation failure also.

**4) Dirt:** blocks the cooling fans leading to rise in temperature of the electric motor. In addition, the insulating value of winding insulation can be affected.

**5) Low Insulation Resistance:** causes insulation performance to degrade at an alarming level.

**6) Electrical overload:** Electrical motors draw more current than their overall capacity at different operating conditions. This unpredictable event will happen very suddenly and will greatly impact the motor.

### Conventional Control of Electric Motors

The various needs of electric motors include: frequent starts and stops operation, periodic reversal of direction of rotation, high-starting torque requirement, constant speed, variable speed, etc. These needs would be adequately met if proper motor control system is designed

and implemented. Maintaining the speed of motor at the desired value is what is entailed by speed control of electric motor.

Conventional speed control of ac drive (drive system with ac motor as a prime mover) deals with, changing the speed of the electric drive motor to the required value, by altering certain electric motor speed governing factors. The conventional speed control implies manual control of the speed of the motor, normally achieved without employing solid state device. Speed control of the motor can be achieved by varying the input parameters of the motor such as current, voltage, frequency etc. which can be achieved by various methods such as field control method, armature control method, Ward Leonard method etc. for dc motors and ac motors (Suneeth and Usha, 2014).

According to Tripathi, Singh and Yadav (2015), control of processes and systems in the industry over the years, is customarily done by through conventional proportional-integral-derivative (PID) controllers because of its simplicity, low cost design and robust performance in wide operating conditions. However, conventional control of electric motors suffers from transient and steady state problems like overshoot, settling time and rise time.

In conventional control of motors lag compensator is also used to improve the steady state error while nearly preserving its transient response. Linda (2015), defines the compensator as a block which is incorporated in the system (motor drive system) so that it alters the overall transfer function of the system in such a way to obtain the required characteristics. As observed by Tripathi, Singh and Yadav (2015), though various technologies and modifications have been employed to overcome these difficulties such as auto tuning of proportional-integral-derivative (PID) controllers, adaptive techniques and compensation techniques, however, automatic tuning procedures are required for satisfactory control of controller parameters, which would necessitate an advance control scheme.

### Advance Control Schemes of Electric Motors for Performance and Prolongation

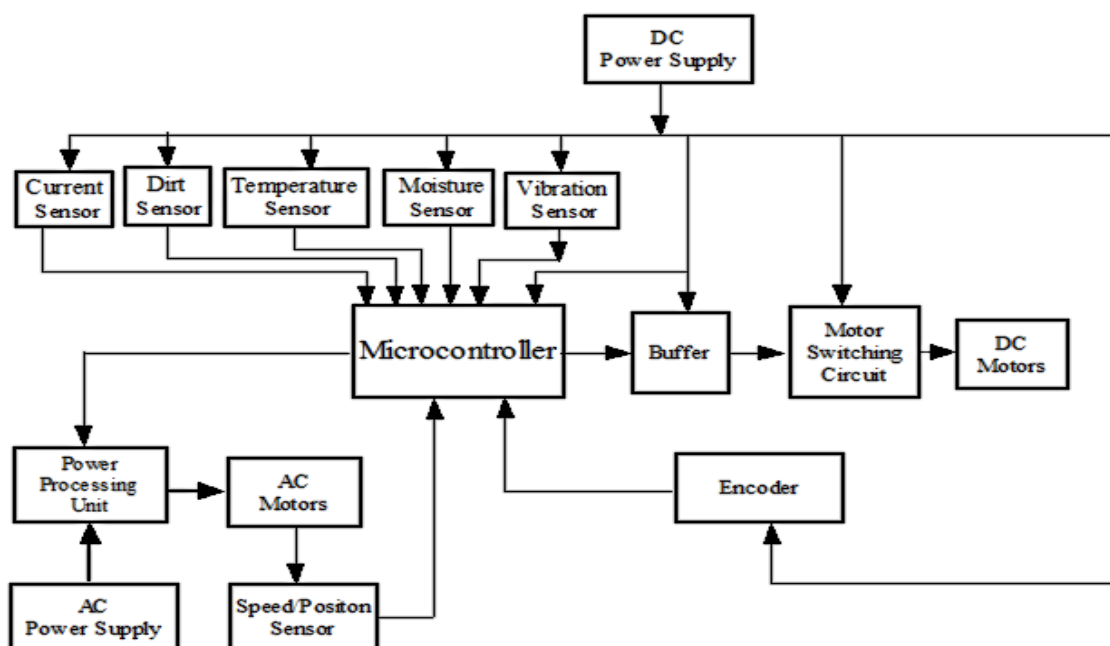

Figure 2. Block diagram of protection scheme against electric motors failure and for improved performance

### Practical Advance Control of ac Electric Motors for Performance and Prolongation

The advance control mode is applicable to ac 3-phase induction motors having  $a-b-c$  windings. This mode entails transforming the  $a-b-c$  winding quantities to equivalent  $dq$ -windings (Figure 3) in order to analyze non steady state conditions of the induction motors. Mohan (2014) explain this mode by stating that the actual stator phase windings and the equivalent rotor phase windings are represented by an equivalent set of  $dq$  windings, which produce the same air gap magnetomotive force (mmf). Due to their orthogonal orientation there is no magnetic coupling between the windings on the  $d$ -axis and those on the  $q$ -axis, resulting in much simpler expressions for modelling. In addition, it allows air gap flux and electromagnetic torque to be controlled independently. The independent control of torque is most desirable as it helps to improve the electric motor performance.

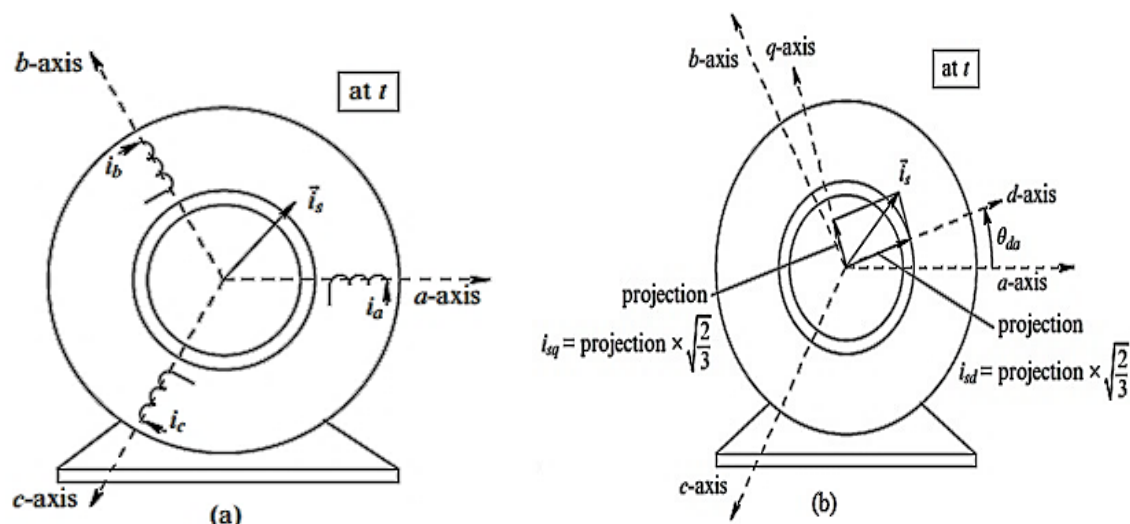

Figure 3. Representation of stator mmf by equivalent dq windings (Mohan, 2014)

### Sample Application of Computer Simulation Aided Control System

Let

- $i_{sd}$  = stator winding current along the  $d$  – axis
- $i_{sq}$  = stator winding current along the  $q$  – axis
- $i_{rd}$  = rotor flux linkages along the  $d$  – axis
- $i_{rq}$  = rotor flux linkages along the  $q$  – axis

been expressed in terms of state variables:

- $\lambda_{sd}$  = stator flux linkages along the  $d$  – axis
- $\lambda_{sq}$  = stator flux linkages along the  $q$  – axis
- $\lambda_{rd}$  = rotor flux linkages along the  $d$  – axis
- $\lambda_{rq}$  = rotor flux linkages along the  $q$  – axis

When compared to the instantaneous changing currents the quantities  $\lambda_{sd}$  ,  $\lambda_{sq}$  ,  $\lambda_{rd}$  ,  $\lambda_{rq}$  changes slowly.

Thus, for  $d$ -axis windings,

$$\begin{bmatrix} \lambda_{sd} \\ \lambda_{rd} \end{bmatrix} = \begin{bmatrix} L_s & L_m \\ L_m & L_r \end{bmatrix} \begin{bmatrix} i_{sd} \\ i_{rd} \end{bmatrix}$$

Similarly, for  $q$ -axis winding

$$\begin{bmatrix} \lambda_{sq} \\ \lambda_{rq} \end{bmatrix} = \begin{bmatrix} L_s & L_m \\ L_m & L_r \end{bmatrix} \begin{bmatrix} i_{sq} \\ i_{rq} \end{bmatrix}$$

Combining the above two matrices:

$$\begin{bmatrix} \lambda_{sd} \\ \lambda_{sq} \\ \lambda_{rd} \\ \lambda_{rq} \end{bmatrix} = \begin{bmatrix} L_s & 0 & L_m & 0 \\ 0 & L_s & 0 & L_s \\ L_m & 0 & L_r & 0 \\ 0 & L_m & 0 & L_r \end{bmatrix} \begin{bmatrix} i_{sd} \\ i_{sq} \\ i_{rd} \\ i_{rq} \end{bmatrix}$$

Letting

$$[M] = \begin{bmatrix} L_s & 0 & L_m & 0 \\ 0 & L_s & 0 & L_s \\ L_m & 0 & L_r & 0 \\ 0 & L_m & 0 & L_r \end{bmatrix}$$

$$\begin{bmatrix} i_{sd} \\ i_{sq} \\ i_{rd} \\ i_{rq} \end{bmatrix} = [M]^{-1} \begin{bmatrix} \lambda_{sd} \\ \lambda_{sq} \\ \lambda_{rd} \\ \lambda_{rq} \end{bmatrix}$$

From which we can draw using Simulink the block diagram for computer modeling as shown in Figure 4.

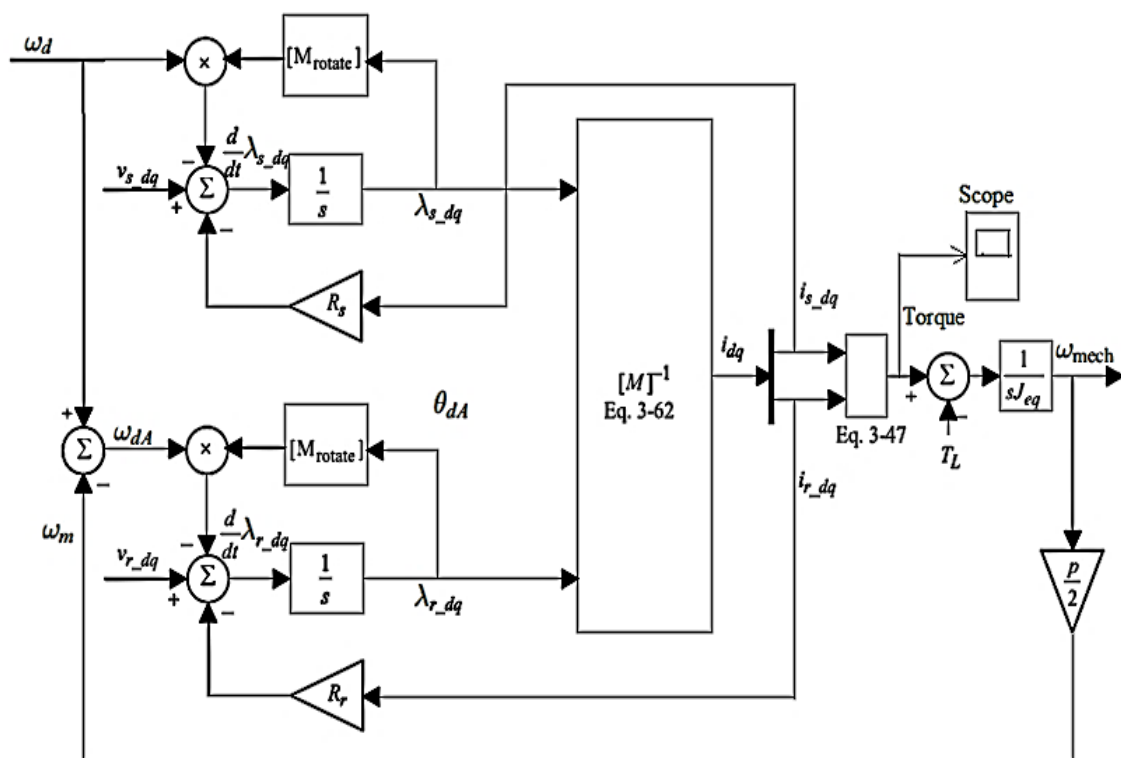

Figure 4. Induction motor model in terms of dq windings (Mohan, 2014)

### The Role of Marketing in Generating Revenue for Electric Motors

In the first instance, there is no product produced that can be sold except if there is a market for such product. A market may be viewed as a point where exchanges takes place. Marketing

is considered as a set of human activities directed at facilitating and consummating mutually satisfying exchange relationship between the market and the market (Kotler and Keller, 2006).

The importance of marketing is viewed to the extent that financial success is said to depend on marketing ability. Finance, operation, accounting and other business functions will not really matter if there is not sufficient demand for product and service so that company can make a profit. According to Koto and Suraju (2006) marketing provides the necessary cash and credit to produce, transport, store, promote, sell and buy products. The foregoing are however achieved through revenue generated from sales. The traditional business focus is to produce and sell to the market (customers) whereas, a firm can never be sure that customers will want to buy its product. Therefore, the modern marketing idea emphasizes the identification and understanding the needs and wants of customers in the market and adapting the operation of the organization to deliver the right goods and services more effectively and efficiently than its competitors for their satisfaction and mutual benefit.

In line with this, Nigeria manufacturing industries are operating in a highly competitive and rapidly changing environment. In the changing economic scenario, a professional approach to business development is essential and the survival of the industries depends on its ability to take up challenges coming up in the environment. Developing business through the use of electric motors in the manufacturing industries is one of the crucial areas which need attention of the industries to ensure profitable survival. Positioning in marketing seeks to place the product in the minds of prospective buyers. Once the benefits of using electric motors is adequately positioned in the minds of manufacturers, repeat purchase is assured and this guarantees savings in promotional expenditure. This is so because what will be required would be a reminder type of promotion. The manufacturers do not need persuasive promotion to be able to buy electric motors.

### Findings

The finding reveals that:

- i) The findings reveal that poor performance and reduced life-span is as a result of zero or poor control of the electric motors.
- ii) Using advanced control system approach aided by computer simulation application compared to the conventional method of control of electric motors entails modeling, analyzing and controlling electric motors using orthogonal dq-axis transformation of the electric motor phase windings.

### Conclusion

This study focuses on the need to sustain production in Nigerian manufacturing industries using feedback control systems application to electric motors aimed at improving their performance and prolongation. The study discussion seeks to bring to the awareness of industrial operatives and stakeholders the need to adopt advanced control mode for ac motors increased performance in addition to the conventional methods normally used.

The use of feedback control of electric motors via unitized sensors in prolonging the usage of the motors was illustrated. Example step procedure for the modelling and simulation of these motors with the view of tuning them for better performance was outlined.

### Recommendation

The discussions from study therefore led to the following recommendations:

- i) The use of unitized sensor monitoring feedback control system to reduce the failure rate of electric motors. Though the initial cost might be expensive but on the long run saves cost of production.
- ii) Adequate sensitization should be carried out by the Manufacturers Association of Nigeria (MAN) on the need to optimize electric motors usage in industries.
- iii) Once the benefits of using electric motors is adequately positioned in the minds of manufacturers, repeat purchase is assured and revenue will be generated.
- iv) The incorporate of advance control strategy by all Nigeria manufacturing industries will revolutionized the industries.

## References

1. Dorf, R.C. and Bishop, R.H. 2008. Modern Control System. London: Pearson Education, Ltd.
2. Factors Affecting Motor Performance. 2018, June 14. Retrieved from <https://www.mabuchi-motor.com/product/knowledge/performance/factors.html>.
3. Keyes, C. 2007. Electric Motors Energy Efficiency Reference Guide, May 14, 2018, from <http://what-when-how.com/electric-motors/the-importance-of-electric-motor-drives/>
4. Kofo, O. and Suraju, A.A. 2006. Marketing management planning and control (Texts Insights) Lagos: Sundoley Press Nig. Ltd.
5. Kotler, P. and Keller, L.K. 2006. Marketing management. 12<sup>th</sup> Edition, New Jersey, Pearson Education Inc.
6. Linda, C.S. 2015. Analysis and Design of Conventional Controller for Speed Control of DC Motor -A MATLAB Approach. Journal of Engineering Research and Applications, 5, 56-61.
7. Mirza, U. 2013. Determining Causes for Electric Motor Failure, July 3, 2018, from <https://www.brighthubengineering.com/commercial-electrical-applications/78579-determining-causes-for-electric-motor-failure/>
8. Mohan, N. 2014. Advanced Electric Drive-Analysis, Control and Modeling Using Matlab/Simulink: John Wiley & Sons, Inc.
9. Sao, K. and Kumar Singh, D. 2015. A Review of Transient and Steady State Response of DC Motor Position Control. International Journal of Engineering Research and Technology, 4(6): 756-762.
10. Suneeth, R. and Usha, P. 2014. Speed Control of Single Phase Induction Motor Using AC Chopper by Asymmetrical PWM Method. International Journal of Advanced Research in Electrical, Electronics and Instrumentation Engineering, 3(10): 12415-12422.
11. Tripathi, N., Singh, R. and Yadav, R. 2015. Analysis of Speed Control of DC Motor –A review study. International Research Journal of Engineering and Technology, 2(8): 1616-1621.